

# 2022 WATERMASTER FILTRATION



PURVEYORS OF THE FINEST IRRIGATION SUPPLIES



## BAFSCO™ DRAGON FILTERS PRESSURE GALVANIZED



### BAFSCO™ DRAGON FILTERS 475 GPM

PART #	DESCRIPTION	LIST
<b>Center Outlets Up or Down</b>		
DF44F4FC	4" Flanged Inlet, 4" Flanged Center Outlet	1,450.00
DF46F6FC	6" Flanged Inlet, 6" Flanged Center Outlet	1,450.00
DF46F6RLC	6" Flanged Inlet, 8" Ringlock Center Outlet	1,450.00
DF46P6PC	6" Plain Inlet, 6" Plain Center Outlet	1,450.00
<b>End Outlets Up or Down</b>		
DF44F4FE	4" Flanged Inlet, 4" Flanged End Outlet	1,450.00
DF46F6FE	6" Flanged Inlet, 6" Flanged End Outlet	1,450.00
DF46F6RLE	6" Flanged Inlet, 6" Ringlock End Outlet	1,450.00
DF46P6PE	6" Plain Inlet, 6" Plain End Outlet	1,450.00
DF4SO62	1/16" Filter Screen Only	725.00
DF4SO94	3/32" Filter Screen Only	725.00

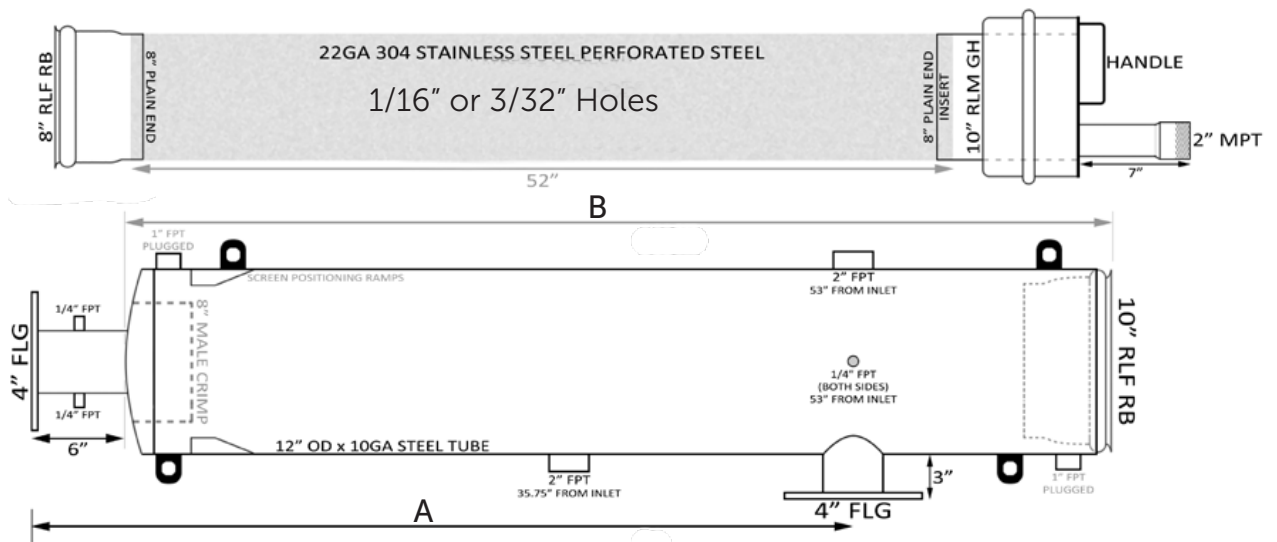

#### FILTER DIMENSIONS

	A	B	C	D	Screen Length	Screen RL to End
END	53.00"	63.75"	6"	3"	52"	55"
CENTER	35.75"	63.75"	6"	3"	52"	55"

## BAFSCO™ DRAGON FILTERS PRESSURE GALVANIZED



### BAFSCO™ DRAGON FILTERS 700 GPM

PART #	DESCRIPTION	LIST
<b>Center Outlets Up or Down</b>		
DF76F6FC	6" Flanged Inlet, 6" Flanged Center Outlet	1,750.00
DF76F8FC	6" Flanged Inlet, 8" Flanged Center Outlet	1,750.00
DF78F8FC	8" Flanged Inlet, 8" Flanged Center Outlet	1,750.00
DF76F8RLC	6" Flanged Inlet, 8" Ringlock Center Outlet	1,750.00
DF78F8RLC	8" Flanged Inlet, 8" Ringlock Center Outlet	1,750.00
DF78P8PC	8" Plain Inlet, 8" Plain Center Outlet	1,750.00
<b>End Outlets Up or Down</b>		
DF76F6FE	6" Flanged Inlet, 6" Flanged End Outlet	1,750.00
DF76F8FE	6" Flanged Inlet, 8" Flanged End Outlet	1,750.00
DF78F6FE	8" Flanged Inlet, 6" Flanged End Outlet	1,750.00
DF78F8FE	8" Flanged Inlet, 8" Flanged End Outlet	1,750.00
DF76F8RLE	6" Flanged Inlet, 8" Ringlock End Outlet	1,750.00
DF78F8RLE	8" Flanged Inlet, 8" Ringlock End Outlet	1,750.00

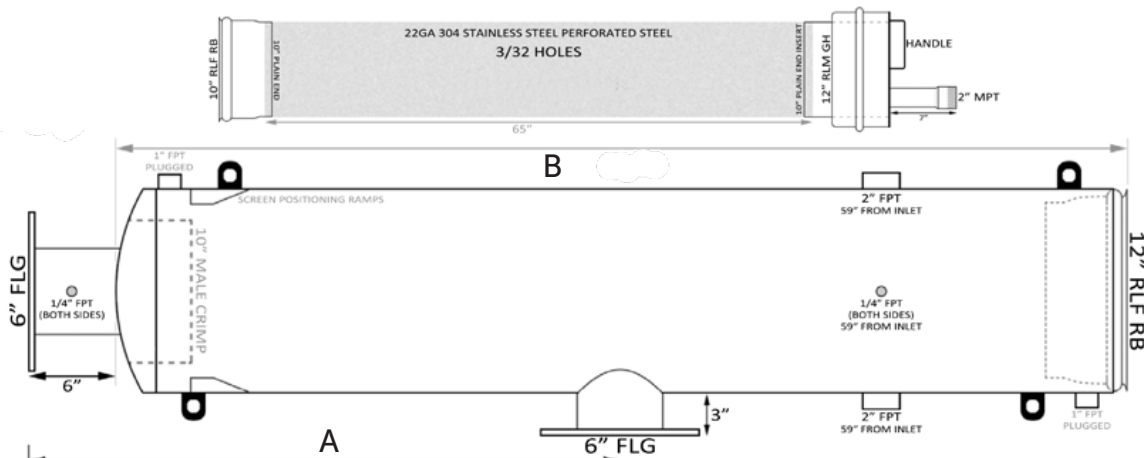

#### FILTER DIMENSIONS

	A	B	C	D	Screen Length	Screen RL to End
END	59"	70"	6"	6"	65"	68"
CENTER	41"	70"	6"	6"	65"	68"

## BAFSCO™ DRAGON FILTERS PRESSURE GALVANIZED

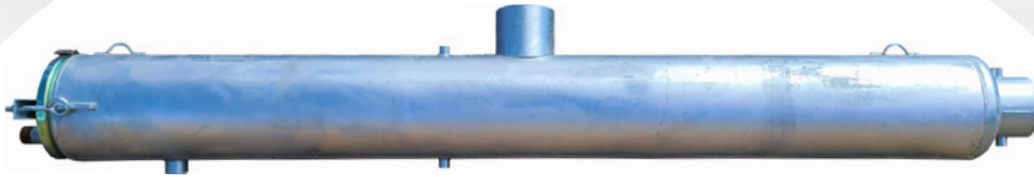

### BAFSCO™ DRAGON FILTERS 1200 GPM

PART #	DESCRIPTION	LIST
DF128P8PC	8" Plain Inlet , 8" Plain Center Outlet	2,500.00
DF128P8PE	8" Plain Inlet, 8" Plain End Outlet	2,500.00
DF128P8WO	8" Plain Inlet, 8" Weld On Outlet	2,500.00
DF128F8FC	8" Flanged Inlet, 8" Flanged Center Outlet	2,585.00
DF128F8RLC	8" Flanged Inlet, 8" Ringlock Outlet	2,585.00
DF128F8FE	8" Flanged Inlet, 8" Flanged End Outlet	2,585.00
DF12KIT	Air vent, 2 Pressure Gauges 160 psi, Brass Gate Valve	Included

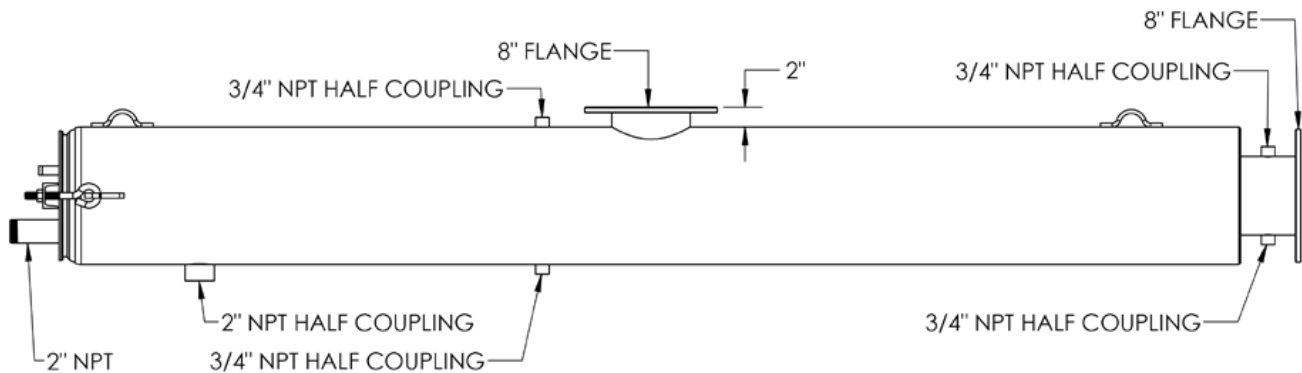

#### FILTER DIMENSIONS

	A	B	C	D	E	F
END	112.25"	126.41"	8"	14"	6.38"	8"
CENTER	66.25"	126.41"	8"	14"	6.38"	8"

- 3/32" PERFORATED SCREEN STANDARD - 20 GAUGE STAINLESS - WELDED SEAM
- REPLACEMENT SCREENS ARE INTERCHANGEABLE W/ CLEMONS 1200A
- ALL GALVANIZED AND STAINLESS
- RING BAND LOCK AND SAFETY BAR STANDARD ON 1200 GPM
- 0-125 WORKING PRESSURE
- DUAL 3/4" NPT PRESSURE GAUGE PORTS
- DUAL LIFTING EYES
- 8" INLET AND OUTLET MADE OF 1/4" WALL PIPE
- 2" MALE NPT BLOW OFF PORT
- .125" THICK 14" TUBE

## BAFSCO™ DRAGON FILTERS PRESSURE GALVANIZED



### BAFSCO™ DRAGON FILTERS 2000 GPM

PART #	DESCRIPTION	LIST
DF2000	10" Flanged Inlet , 10" Flanged Center Outlet	4,125.00

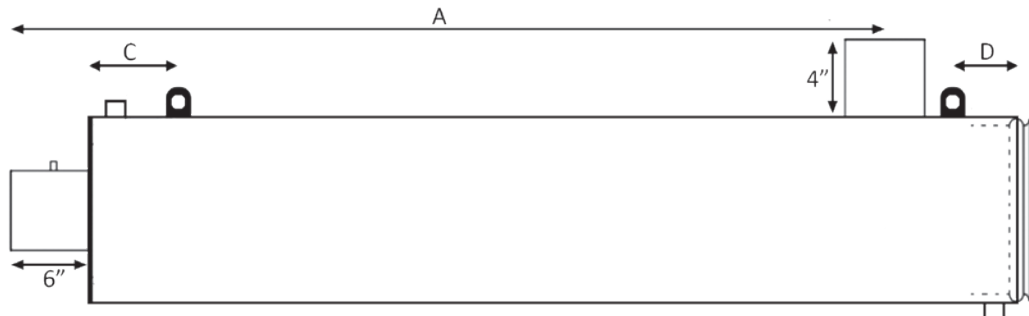

### FILTER DIMENSIONS

	A	B	C	D	Body Size	Blow Off Port
CENTER	62"	117"	6"	6"	16"	3"



### FILTER REPLACEMENT PARTS

PART #	DESCRIPTION	LIST
DF7S062	1/16" Filter Screen for 700	825.00
DF7S094	3/32" Filter Screen for 700	825.00
DF12S062	1/16" Filter Screen for 1200	1,250.00
DF12S094	3/32" Filter Screen for 1200	1,250.00
DF12S250	1/4" Filter Screen for 1200	1,250.00
DF2S094	3/32" Filter Screen for 2000	2,000.00
DFCB	Cross Bar for 1200	100.00
DFEB	Eyebolt for 1200	100.00
12RLC	12" Ringlock Clamp	45.00
Pressure Gauges see Industrial Section		

## BAFSCO™ WATERMASTER™ SELF CLEANING SUCTION SCREEN



### WATERMASTERS

PART# MODEL	CAPACITY GPM	INTAKE SIZE	CAN HEIGHT	SCREEN SIZE	FILTER SIZE	FILTER GPM	WEIGHT	LIST PRICE
WM18	400	6"	11"	18"	1"	0-40	68 LBS	1,550.00
WM24	800	8"	15"	24"	1 1/2"	0-60	100 LBS	1,800.00
WM30	1250	10"	17"	30"	2"	0-90	186 LBS	2,415.00
WM36	1800	12"	17"	36"	2"	0-90	240 LBS	2,915.00

- ALL GALVANIZED CONSTRUCTION WITH A HEAVY DUTY STEEL BODY
- #3 EXPANDED METAL STEEL LID COVERED BY #8 MESH, 20 GAUGE STAINLESS CLOTH SCREEN
- NOTE - THE #8 MESH SCREEN REDUCES THE SUCTION AREA BY APPROXIMATELY 50%
- ALL WATERMASTERS COME WITH A CHROME SLEEVED BEARING FOR LONGER WEAR
- WATERMASTERS COME WITH A SET OF STAINLESS STEEL CAMLOCKS FOR EASY REMOVAL, REPLACEMENT OR INSPECTION OF BEARING/WAND
- 36" WATERMASTERS FEATURE LID HOOKS TO HOLD THE LIDS ON
- COMPONENTS FOR INSTALLATION:
  - 20' GOODYEAR HOSE
  - 4X 667-12 1" CLAMP
  - 4X 306-100 1" KING NIPPLE
  - ACTION FILTER WITH #16 MESH STAINLESS STEEL SCREEN
  - FILTER MOUNTING BRACKET
  - 1" BRASS GATE VALVE
  - 1" WELD-ON NIPPLE

### GPM REQUIRED FOR SPINNER ARM

PSI AT PUMP	35	40	45	50	55	60	65	70	75	80
WM18 - 6 HOLE	20.4	21.7	23.1	24.3	25.4	26.6	27.6	28.8	30.0	31.2
WM24 - 9 HOLE	30.6	32.4	34.2	36.9	37.8	39.6	41.4	43.2	45.0	45.9
WM30 - 11 HOLE	37.4	39.6	41.8	45.1	46.2	48.4	50.6	52.8	55.0	56.1
WM36 - 11 HOLE	37.4	39.6	41.8	45.1	46.2	48.4	50.6	52.8	55.0	56.1

## BAFSCO™ WATERMASTER™ PARTS



WATERMASTER FILTERS		
PART #	SIZE	LIST
WM300-10	For 18"	61.95
WM300-15	For 24"	87.50
WM300-20	30" & 36"	134.15
1" Female threads 16 mesh screen		

WATERMASTER COMPLETE ARMS		
PART #	SIZE	LIST
WM18CA	18" 6 Hole	36.65
WM24CA	24" 9 Hole	38.90
WM30CA	30" 11 Hole	41.10
WM36CA	36" 11 Hole	43.35
WM105	Galv. Adapter to Bearing	8.50

WATERMASTER BEARINGS		
PART #	SIZE	LIST
WM108726	1" NPT	55.00
WM108726CS	1" NPT	60.55
CS = Chrome Sleeve Heavy Duty Bearing		

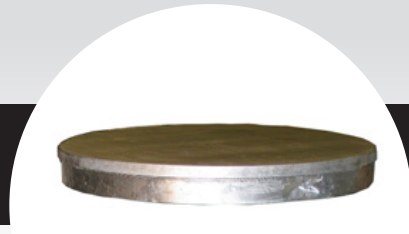

FILTER MOUNTING BRACKET		
PART #	SIZE	LIST
WM107		25.00

WATERMASTER HOSE		
PART #	SIZE	LIST PER FT.
MPH100	1" 150 psi	4.30
667-12	1" Clamp	2.25
306-100	1" King Nipple	2.95

WATERMASTER LIDS		
PART #	SIZE	LIST
WM118	18"	290.00
WM124	24"	340.00
WM130	30"	460.00
WM136	36"	512.00



GATE VALVE AND CAMLOCKS		
PART #	SIZE	LIST
BGV-100	1"	20.85
310AS	1" A Type SS Camlock	13.60
310BS	1" B Type SS Camlock	24.60

WELD ON NIPPLE		
PART #	SIZE	LIST
WM104	1"	7.25

MESH SCREEN ONLY		
PART #	SIZE	LIST
WM118SO	18"	100.00
WM124SO	24"	115.00
WM130SO	30"	145.00
WM136SO	36"	165.00

# LAKOS® PC-SELF-CLEANING INTAKE SCREEN



## SELF-CLEANING PUMP INTAKE SCREENS

PART# MODEL	CAPACITY GPM	INTAKE SIZE	OVER ALL HEIGHT	SCREEN MESH	REQUIRED BACKWASH	LINE SIZE	BACKWASH FLOW RATE	WEIGHT	LIST PRICE
PC915	350	6"	19"	10, 18	55-80 PSI	1 1/4"	10 GPM	27	CALL
PC1415	560	6"	24"	10, 18	60-80 PSI	1 1/4"	15 GPM	29	
PC924	650	10"	19 1/2"	10, 18	60-100 PSI	1 1/4"	12 GPM	50	
PC1424	1,000	10"	24 1/2"	10, 18	65-100 PSI	1 1/2"	18 GPM	53	
PC1924	1,350	10"	29 1/2"	10, 18	70-100 PSI	1 1/2"	25 GPM	55	
PC2424	1,700	12"	34 1/2"	10, 18	75-100 PSI	1 1/2"	36 GPM	65	
PC2924	2,050	12"	34 1/2"	10, 18	75-100 PSI	2"	41 GPM	75	
PC3424	2,400	16"	47"	10, 18	75-100 PSI	2"	50 GPM	89	

- EPOXY COATED OR STAINLESS STEEL
- 30 MESH SCREEN AVAILABLE AT LOWER FLOW RATES

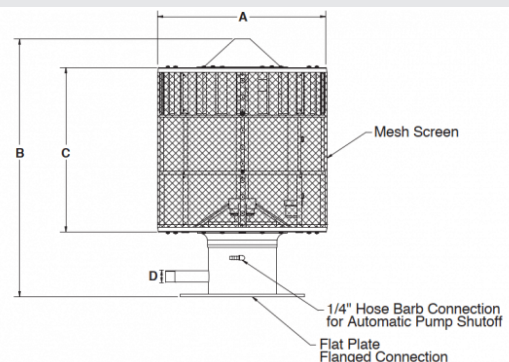
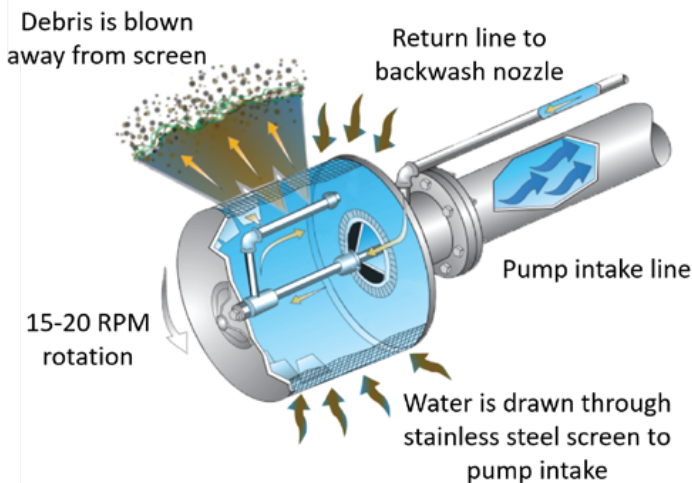

MODEL	A	B	C	D
PC915	14 15/16"	17 11/16"	9 9/16"	3/4"
PC1415	14 15/16"	22 3/4"	14 9/16"	3/4"
PC924	24 1/4"	20 1/16"	9 1/2"	1"
PC1424	24 1/4"	25 1/16"	14 1/2"	1"
PC1924	24 1/4"	28 13/16"	19 3/8"	1"
PC2424	24 1/4"	34 5/8"	24 5/8"	1"
PC2924	24 1/4"	40 3/16"	29 1/2"	1"
PC3424	24 1/4"	45 3/8"	34 3/8"	1"



# LAKOS® ILB-ILS SEPARATORS



## ILB-ILS SEPARATORS

PART# MODEL	CAPACITY GPM	INLET/ OUTLET	PURGE OUTLET	OVER ALL HEIGHT	WEIGHT	LIST PRICE
ILB/ILS-0037	3-6	3/8"	3/4"	16 1/2"	9	CALL
ILB/ILS-0050	4-10	1/2"	3/4"	20"	14	
ILB/ILS-0075	10-20	3/4"	3/4"	20"	16	
ILB/ILS-0100	19-32	1"	3/4"	30"	27	
ILB/ILS-0125	28-48	1 1/4"	3/4"	30"	27	
ILB/ILS-0150	45-70	1 1/2"	3/4"	30"	27	
ILB/ILS-0200	65-108	2"	3/4"	33 5/8"	55	
ILB/ILS-0250	95-155	2 1/2"	3/4"	37"	60	
ILB/ILS-0300	148-290	3"	3/4"	42"	135	

MAXIMUM PRESSURE: 150 PSI (10.3 BAR)

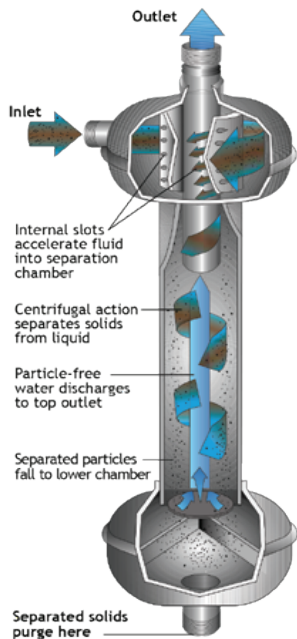

- NO MOVING PARTS TO WEAR OUT OR REPLACE
- NO SCREENS, CARTRIDGES, CONES, OR FILTER ELEMENTS TO CLEAN OR REPLACE
- CENTRIFUGAL SEPARATOR PATENTED TECHNOLOGY
- NO BACKFLUSHING OR DOWNTIME REQUIREMENTS
- PRESSURE LOSS AS LOW AS 5 PSID
- HEAVY DUTY CONSTRUCTION, AVAILABLE IN RUGGED CARBON STEEL (MODEL ILB) OR STAINLESS STEEL (MODEL ILS)

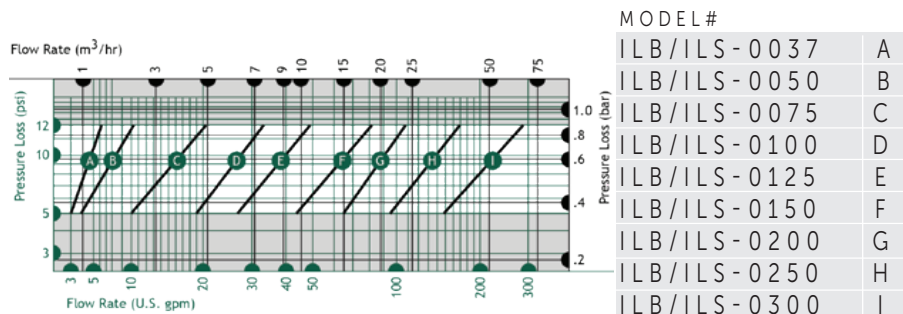

## SURE-FLO® SELF CLEANING STRAINERS



.097 SCREEN

### SINGLE DRIVE

PART #	GPM	LIST
SCS3	160	711.25
SCS4	325	818.75
SCS6	625	1,773.75
SCS8	1150	2,220.00
SCS10	1500	3,071.25
SCS10BB	1900	3,621.25
SCS10XL	2500	4,103.75
SCS12XL	2500	4,242.50

Requires 60-65 psi and  
8-77 gpm for self cleaning



.097 SCREEN

### DUAL DRIVE

PART #	GPM	LIST
SCS3-DD	200	751.25
SCS4-DD	400	868.75
SCS6-DD	725	1,852.50
SCS8-DD	1450	2,328.75
SCS10-DD	1875	3,341.25
SCS10BB-DD	2350	3,931.25
SCS10XL-DD	2950	4,263.75
SCS12XL-DD	2950	4,410.00

Requires 45-55 psi and  
14-96 gpm for self cleaning

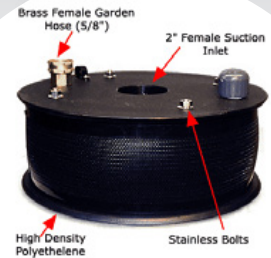

### SINGLE DRIVE

PART #	GPM	LIST
SCS2	50	355.00

How This Self-Cleaning Strainer Works  
A small amount of water is returned from the pressure side of the pump to the strainer. Inside, two special nozzles spray against the screen, causing it to revolve. Any debris attracted to the screen is blasted off every half revolution. Strainers operate in any position, and require 35 psi to operate.

## FOOT VALVES FOR SELF CLEANING STRAINERS



### FOOT VALVE - OD TUBING

PART #	SIZE	LIST
SFV3WCT	3" 45°	308.75
SFV4WCT	4" 45°	303.15
SFV6WCT	6" 45°	563.75
SFV8WCT	8" 45°	843.75
SFV10WCT	10" 45°	1,285.00
SFVV3WCT	3"	315.00
SFVV4WCT	4"	365.00
SFVV6WCT	6"	618.75
SFVV8WCT	8"	888.75
SFVV10WCT	10"	1,325.00

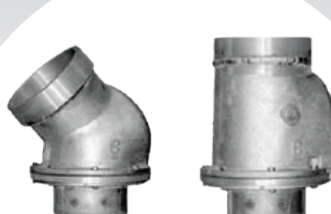

### FOOT VALVE - FPT

PART #	SIZE	LIST
SFV3FPWCT	3" 45°	341.25
SFV4FPWCT	4" 45°	418.75
SFV6FPWCT	6" 45°	717.50
SFV8FPWCT	8" 45°	1,042.50
SFV10FPWCT	10" 45°	1,443.75
SFVV3FPWCT	3"	360.95
SFVV4FPWCT	4"	373.75
SFVV6FPWCT	6"	768.75
SFVV8FPWCT	8"	1,043.75
SFVV10FPWCT	10"	1,613.75



### FOOT VALVE - FLANGED

PART #	SIZE	LIST
SFV3CFWCT	3" 45°	372.50
SFV4CFWCT	4" 45°	501.25
SFV6CFWCT	6" 45°	728.75
SFV8CFWCT	8" 45°	1,141.25
SFV10CFWCT	10" 45°	1,491.25
SFVV3CFWCT	3"	386.25
SFVV4CFWCT	4"	522.50
SFVV6CFWCT	6"	796.25
SFVV8CFWCT	8"	1,175.00
SFVV10CFWCT	10"	1,510.00

## SURE-FLO® FOOT VALVES



**45° OD TUBING**

PART #	SIZE	LIST
SFV2	2"	242.50
SFV3	3"	308.75
SFV4	4"	367.50
SFV5	5"	497.50
SFV6	6"	608.75
SFV8	8"	926.25
SFV10	10"	1,468.75



**45° FEMALE THREAD**

PART #	SIZE	LIST
SFV2FP	2"	261.25
SFV3FP	3"	341.25
SFV4FP	4"	427.50
SFV5FP	5"	657.50
SFV6FP	6"	762.50
SFV8FP	8"	1,123.75
SFV10FP	10"	1,627.50



**45° COMPANION FLANGE**

PART #	SIZE	LIST
SFV2CF	2"	317.50
SFV3CF	3"	497.50
SFV4CF	4"	508.75
SFV5CF	5"	655.00
SFV6CF	6"	776.25
SFV8CF	8"	1,222.50
SFV10CF	10"	1,672.50



**VERTICAL OD TUBING**

PART #	SIZE	LIST
SFVV3	3"	315.00
SFVV4	4"	373.75
SFVV5	5"	575.00
SFVV6	6"	666.25
SFVV8	8"	972.50
SFVV10	10"	1,507.50



**VERTICAL FEMALE THREAD**

PART #	SIZE	LIST
SFVV2FP	2"	226.25
SFVV3FP	3"	297.50
SFVV4FP	4"	382.50
SFVV5FP	5"	708.75
SFVV6FP	6"	815.00
SFVV8FP	8"	1,128.75
SFVV10FP	10"	1,793.75



**VERTICAL FLANGE**

PART #	SIZE	LIST
SFVV2CF	2"	326.25
SFVV3CF	3"	386.25
SFVV4CF	4"	531.25
SFVV5CF	5"	712.50
SFVV6CF	6"	842.50
SFVV8CF	8"	1,260.00
SFVV10CF	10"	1,693.75

## SURE-FLO® STRAINERS



**OD TUBING**

PART #	SIZE	LIST
SFS2	2"	57.50
SFS3	3"	67.50
SFS4	4"	92.50
SFS5	5"	128.75
SFS6	6"	156.25
SFS8	8"	262.50
SFS10	10"	348.75
SFS12XL	12"	1,332.50



**PVC PIPE**

PART #	SIZE	LIST
SPVC4	4"	146.25
SPVC6	6"	217.50
SPVC8	8"	287.50
SPVCJ8	8"	482.50
SPVC10	10"	458.75
SPVC12	12"	1,132.50
SPVC15	15"	1,132.50
SPVC16	16"	1,132.50



**THREADED**

PART #	SIZE	LIST
SFS2P	2"	91.25
SFS25P	2 1/2"	93.75
SFS3P	3"	101.25
SFS4P	4"	161.25
SFS4P-S	4" w/ Slide	192.50
PLS2	2"	153.75
PLS2-OS	2"	170.00
PLS3	3"	336.25



**COMPANION FLANGE**

PART #	SIZE	LIST
SFSF2	2"	126.25
SFSF3	3"	187.50
SFSF4	4"	207.50
SFSF6	6"	271.25
SFSF8	8"	480.00
SFSF10	10"	1,153.75
SFSF12	12"	1,153.75



**SUBMERSIBLE PUMP**

PART #	SIZE	LIST
SPS4	4" Strainer	162.50
SPS6	6" Strainer	261.25
SPS8	8" Strainer	318.75
PSP4-1	4" x 1" NPT	70.00
PSP6-1	6" x 1" NPT	117.50
PSP6-2	6" x 2" NPT	117.50
PSP8-2	8" x 2" NPT	133.75



**LIQUID MANURE**

PART #	SIZE	LIST
SFLMS4	4"	567.50
SFLMS5	5"	567.50
SFLMS6	6"	567.50
SFLMS8	8"	567.50
SFLMS10	10"	567.50

## SURE-FLO® FITTINGS



### 90° SUCTION ELBOWS

PART #	SIZE	LIST
SFE92	2"	150.00
SFE93	3"	188.75
SFE94	4"	233.75
SFE95	5"	322.50
SFE96	6"	352.50
SFE98	8"	538.75
SFE910	10"	850.00

### 45° SUCTION ELBOWS

PART #	SIZE	LIST
SFE42	2"	138.75
SFE43	3"	188.75
SFE44	4"	216.25
SFE45	5"	306.25
SFE46	6"	331.25
SFE48	8"	475.00
SFE410	10"	837.50

### INTAKE COUPLER

PART #	SIZE	LIST
SFC2	2"	76.25
SFC3	3"	90.00
SFC4	4"	96.25
SFC5	5"	143.75
SFC6	6"	152.50
SFC8	8"	237.50
SFC10	10"	325.00

## FOOT VALVE PARTS



### STAINLESS SCREENS

PART #	SIZE	LIST
SOV2-SS	2"	35.00
SOV3-SS	3"	64.15
SOV4-SS	4"	97.00
SOV5-SS	5"	131.60
SOV6-SS	6"	167.85
SOV8-SS	8"	323.25
SOV10-SS	10"	486.50

### ALUMINUM SCREENS

PART #	SIZE	LIST
SOV2	2"	7.75
SOV3	3"	15.15
SOV4	4"	24.10
SOV5	5"	30.25
SOV6	6"	38.40
SOV8	8"	74.60
SOV10	10"	108.60

### SURE FLO GASKET

PART #	SIZE	LIST
373-21	2"	16.20
373-31	3"	22.15
373-41	4"	26.15
373-51	5"	30.95
373-61	6"	52.30
373-81	8"	81.50
373-101	10"	167.10

## AFI CLEAR ACTION FILTERS



MODEL	INLET & OUTLET	FLOW IN GPM	P.S.I. LOSS	L & W
AFI 1.0	1"	0-40	3.3 @ 20GPM	9"X5"
AFI 1.5	1 1/2"	0-60	2.4 @ 35GPM	12"X5 1/2"
AFI 2.0	2"	0-90	3.7 @ 60GPM	13 3/4"X6 1/4"

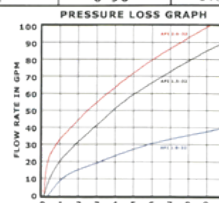

### 1" CLEAR ACTION FILTER

PART #	MESH	LIST
300-10-8	8	67.45
300-10-16	16	67.45
300-10-32	32	66.40
300-10-50	50	66.40
300-10-100	100	66.40
300-10-150	150	66.40
300-10-200	200	66.40

### 1 1/2" CLEAR ACTION FILTER

PART #	MESH	LIST
300-15-8	8	93.30
300-15-16	16	93.30
300-15-32	32	89.85
300-15-50	50	89.85
300-15-100	100	89.85
300-15-150	150	89.85
300-15-200	200	89.85

### 2" CLEAR ACTION FILTER

PART #	MESH	LIST
300-20-8	8	144.60
300-20-16	16	144.60
300-20-32	32	142.70
300-20-50	50	142.70
300-20-100	100	142.70
300-20-150	150	142.70
300-20-200	200	142.70



### 1" SCREEN ONLY

PART #	MESH	LIST
303-10-8	8	39.35
303-10-16	16	39.35
303-10-32	32	35.70
303-10-50	50	35.70
303-10-100	100	35.70
303-10-150	150	35.70
303-10-200	200	35.70

### 1 1/2" SCREEN ONLY

PART #	MESH	LIST
303-15-8	8	47.65
303-15-16	16	47.65
303-15-32	32	42.50
303-15-50	50	42.50
303-15-100	100	42.50
303-15-150	150	42.50
303-15-200	200	42.50

### 2" SCREEN ONLY

PART #	MESH	LIST
303-20-8	8	72.60
303-20-16	16	72.60
303-20-32	32	70.20
303-20-50	50	70.20
303-20-100	100	70.20
303-20-150	150	70.20
303-20-200	200	70.20



### BODY ONLY

PART #	SIZE	LIST
301-10	1"	36.85
301-15	1 1/2"	48.50
301-20	2"	78.35

### CLEAR CANISTER

PART #	SIZE	LIST
302-10	1"	33.30
302-15	1 1/2"	45.40
302-20	2"	70.20

### O-RING KIT

PART #	MESH	LIST
304-10	1"	7.00
304-15	1 1/2"	7.00
304-20	2"	7.00

## SAFI SAND SEPARATOR



MODEL	INLET & OUTLET	FLOW IN GPM	P.S.I. LOSS	L & W
SAFI 1.0	1"	5-25	5 @ 20GPM	14" X 5"
SAFI 1.5	1 1/2"	10-40	5.3 @ 30GPM	14 1/2" X 5 1/2"
SAFI 2.0	2"	15-60	6 @ 50GPM	16" X 6 1/4"

**ACTION**  
MACHINING INC.  
Quality Products Made In the U.S.A.

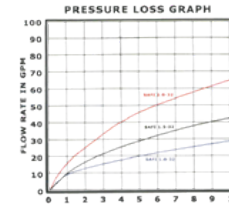

### 1" CLEAR ACTION FILTER

PART #	MESH	LIST
300-10-8SS	8	87.70
300-10-16SS	16	87.70
300-10-32SS	32	85.60
300-10-50SS	50	90.20
300-10-100SS	100	98.70
300-10-150SS	150	101.60
300-10-200SS	200	104.40

### 1 1/2" CLEAR ACTION FILTER

PART #	MESH	LIST
300-15-8SS	8	121.30
300-15-16SS	16	121.30
300-15-32SS	32	115.95
300-15-50SS	50	125.10
300-15-100SS	100	127.50
300-15-150SS	150	130.25
300-15-200SS	200	130.75

### 2" CLEAR ACTION FILTER

PART #	MESH	LIST
300-20-8SS	8	188.00
300-20-16SS	16	188.00
300-20-32SS	32	184.10
300-20-50SS	50	186.25
300-20-100SS	100	190.35
300-20-150SS	150	193.25
300-20-200SS	200	194.65



### 1" SCREEN ONLY

PART #	MESH	LIST
303-10-8SS	8	49.35
303-10-16SS	16	49.35
303-10-32SS	32	47.90
303-10-50SS	50	56.20
303-10-100SS	100	65.20
303-10-150SS	150	68.15
303-10-200SS	200	70.20

### 1 1/2" SCREEN ONLY

PART #	MESH	LIST
303-15-8SS	8	63.85
303-15-16SS	16	63.85
303-15-32SS	32	58.75
303-15-50SS	50	69.05
303-15-100SS	100	71.50
303-15-150SS	150	72.70
303-15-200SS	200	75.70

### 2" SCREEN ONLY

PART #	MESH	LIST
303-20-8SS	8	91.05
303-20-16SS	16	91.05
303-20-32SS	32	89.15
303-20-50SS	50	100.15
303-20-100SS	100	109.20
303-20-150SS	150	112.25
303-20-200SS	200	112.25



### BODY ONLY

PART #	SIZE	LIST
301-10	1"	36.85
301-15	1 1/2"	48.50
301-20	2"	78.35

### CLEAR CANISTER

PART #	SIZE	LIST
302-10SS	1"	41.45
302-15SS	1 1/2"	59.85
302-20SS	2"	87.20

### O-RING KIT

PART #	MESH	LIST
304-10	1"	7.00
304-15	1 1/2"	7.00
304-20	2"	7.00

TERMS: SEE DISCOUNT SCHEDULE. PRICING SUBJECT TO CHANGE WITHOUT NOTICE  
CHECK [HTTP://WWW.BAFISCHER.COM/CATALOGS/](http://www.bafischer.com/catalogs/) FOR CURRENT PRICING

# HDI IN-LINE HIGH VOLUME FILTERS



HDI 50		
PART #	MESH	LIST
HDI 50-8	8	417.20
HDI 50-16	16	417.20
HDI 50-32	32	412.60
HDI 50-50	50	427.20
HDI 50-100	100	441.30
HDI 50-150	150	453.00
HDI 50-200	200	453.00

HDI 100		
PART #	MESH	LIST
HDI 100-8	8	506.30
HDI 100-16	16	506.30
HDI 100-32	32	502.00
HDI 100-50	50	561.60
HDI 100-100	100	576.10
HDI 100-150	150	591.60
HDI 100-200	200	591.60

HDI 150		
PART #	MESH	LIST
HDI 150-8	8	588.85
HDI 150-16	16	588.85
HDI 150-32	32	584.40
HDI 150-50	50	647.40
HDI 150-100	100	671.25
HDI 150-150	150	695.05
HDI 150-200	200	695.05

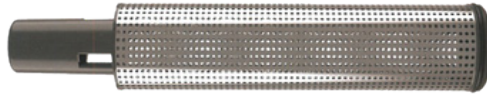

SCREEN ONLY		
PART #	MESH	LIST
HDS 50-8	8	196.35
HDS 50-16	16	196.35
HDS 50-32	32	194.05
HDS 50-50	50	242.80
HDS 50-100	100	262.20
HDS 50-150	150	281.10
HDS 50-200	200	281.10

SCREEN ONLY		
PART #	MESH	LIST
HDS 100-8	8	244.95
HDS 100-16	16	244.95
HDS 100-32	32	242.80
HDS 100-50	50	320.45
HDS 100-100	100	378.75
HDS 100-150	150	436.90
HDS 100-200	200	436.90

SCREEN ONLY		
PART #	MESH	LIST
HDS 150-8	8	302.85
HDS 150-16	16	302.85
HDS 150-32	32	301.05
HDS 150-50	50	451.55
HDS 150-100	100	511.75
HDS 150-150	150	571.85
HDS 150-200	200	571.85

MODEL	INLET & OUTLET	FLOW IN GPM	P.S.I. LOSS	L & W
HDI 50	3"	0-130	1 @ 50GPM	22" X 16"
HDI 100	3"	0-200	2.2 @ 100GPM	34" X 16"
HDI 150	3"	0-270	5.4 @ 150GPM	46" X 16"

- COMES WITH 3" SPIGOT X 2 1/2" SLIP CONNECTION, NEW WHITE PVC MATERIAL.
- SCHEDULE 80 PVC, IDEAL FOR RESIDENTIAL, COMMERCIAL AND INDUSTRIAL USE.
- WATER FLOWS FROM THE OUTSIDE IN FOR EASY SCREEN CLEANING
- 1 1/2" NPT CLEAN OUT
- FULL UNIONIZED BODY

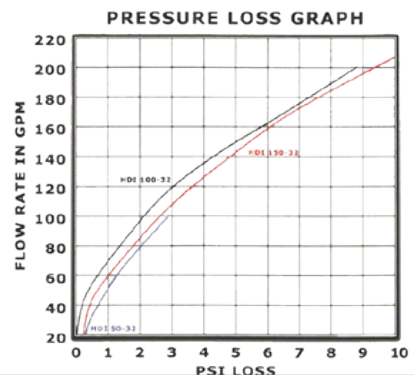



## 90° HIGH VOLUME FILTERS



HD 50		
PART #	MESH	LIST
HD 50-8	8	418.80
HD 50-16	16	418.80
HD 50-32	32	414.25
HD 50-50	50	428.85
HD 50-100	100	443.00
HD 50-150	150	454.80
HD 50-200	200	454.80

HD 100		
PART #	MESH	LIST
HD 100-8	8	484.10
HD 100-16	16	484.10
HD 100-32	32	503.80
HD 100-50	50	563.80
HD 100-100	100	578.35
HD 100-150	150	593.90
HD 100-200	200	593.90

HD 150		
PART #	MESH	LIST
HD 150-8	8	625.15
HD 150-16	16	625.15
HD 150-32	32	621.45
HD 150-50	50	687.35
HD 150-100	100	710.95
HD 150-150	150	735.15
HD 150-200	200	735.15

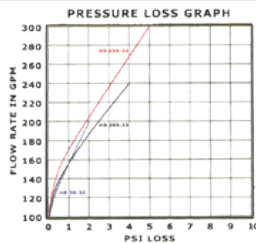

MODEL	INLET & OUTLET	FLOW IN GPM	P.S.I. LOSS	L & W
HD 50	3"	0-160	1 @ 50GPM	20" x 8"
HD 100	3"	0-230	1 @ 100GPM	32" x 8"
HD 150	3"	0-300	1 @ 150GPM	44" x 8"



AFS 50		
PART #	MESH	LIST
AFS 50-8	8	870.10
AFS 50-16	16	870.10
AFS 50-32	32	868.15
AFS 50-50	50	913.25
AFS 50-100	100	931.30
AFS 50-150	150	948.90
AFS 50-200	200	948.90

AFS 100		
PART #	MESH	LIST
AFS 100-8	8	993.75
AFS 100-16	16	993.75
AFS 100-32	32	991.75
AFS 100-50	50	1,063.95
AFS 100-100	100	1,118.15
AFS 100-150	150	1,172.25
AFS 100-200	200	1,172.25

AFS 150		
PART #	MESH	LIST
AFS 150-8	8	1,117.00
AFS 150-16	16	1,117.00
AFS 150-32	32	1,115.35
AFS 150-50	50	1,250.80
AFS 150-100	100	1,304.95
AFS 150-150	150	1,359.05
AFS 150-200	200	1,359.05

- ALL STAINLESS STEEL BODY AND SCREEN
- IDEAL FOR HIGH PRESSURE AND WATER HAMMER
- 2" NPT INLET AND 1 1/2" OUTLET
- 1" NPT CLEAN OUT

**AFI Clear In-Line Filters**

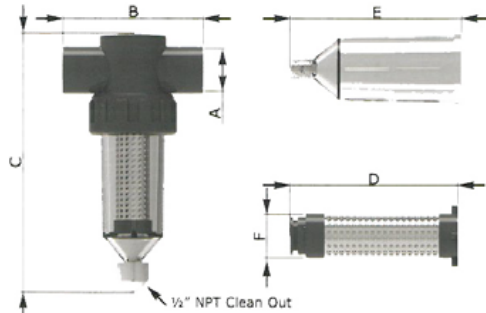

AFI	A	B	C	D	E	F
1.0	1"	5"	9"	5 1/4"	5 7/8"	1 1/4"
1.5	1 1/2"	5 1/2"	12"	6 3/4"	8 3/8"	1 3/4"
2.0	2"	6 1/8"	13 1/2"	8 3/8"	9 3/8"	2"

**SAFI Sand Separator Filters**

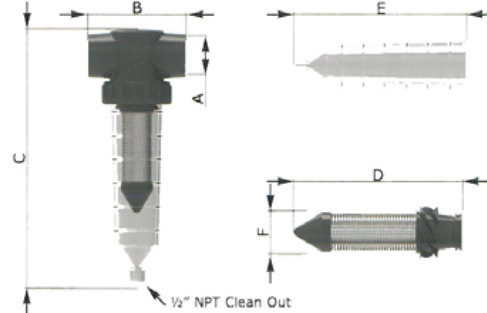

SAFI	A	B	C	D	E	F
1.0	1"	5"	13 3/4"	5 1/2"	10 3/4"	1 1/4"
1.5	1 1/2"	5 1/2"	14 1/2"	7 7/8"	10 7/8"	1 1/2"
2.0	2"	6 1/8"	15 3/4"	8 1/2"	11 1/2"	2"

**HDI High Volume In-Line Filters**

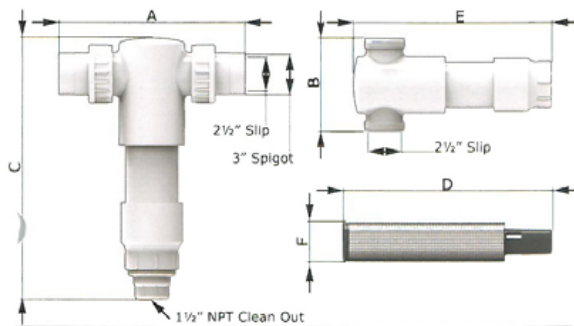

HDI	A	B	C	D	E	F
50	15 3/4"	9 1/8"	22"	16 1/4"	19 1/2"	3"
100	15 3/4"	9 1/8"	34"	28 1/4"	31 1/2"	3"
150	15 3/4"	9 1/8"	46"	40 1/4"	43 1/2"	3"

**HD High Volume 90° Filters**

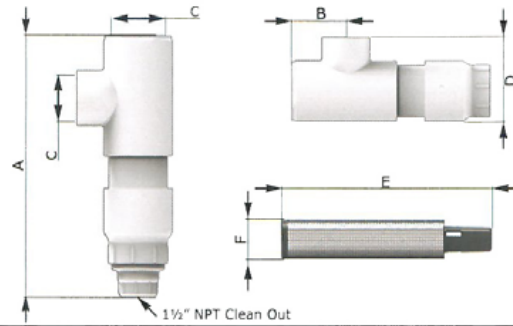

HD	A	B	C	D	E	F
50	19 3/4"	4 5/8"	3"	7"	16 1/4"	3"
100	31 3/4"	4 5/8"	3"	7"	28 1/4"	3"
150	43 3/4"	4 5/8"	3"	7"	40 1/4"	3"

**AFS Stainless Steel Filters**

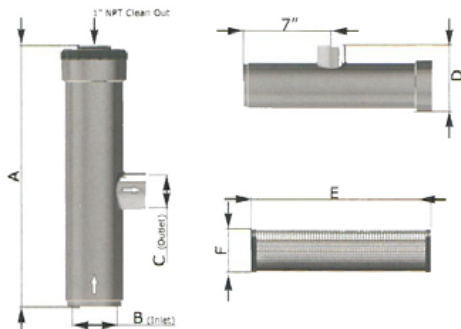

AFS	A	B	C	D	E	F
50	15 3/4"	2"	1 1/2"	5"	12 1/4"	2 3/4"
100	27 3/4"	2"	1 1/2"	5"	24 3/4"	2 3/4"
150	39 3/4"	2"	1 1/2"	5"	36 3/4"	2 3/4"

**Standard Screen Meshes**

MESH	MICRON	SIZE
8	3175	.125"
16	1588	.062"
32	792	.031"
50	292	.009"
100	152	.006"
150	104	.004"
200	74	.003"

# RIVULIS SEMI AUTOMATIC SCREEN FILTER

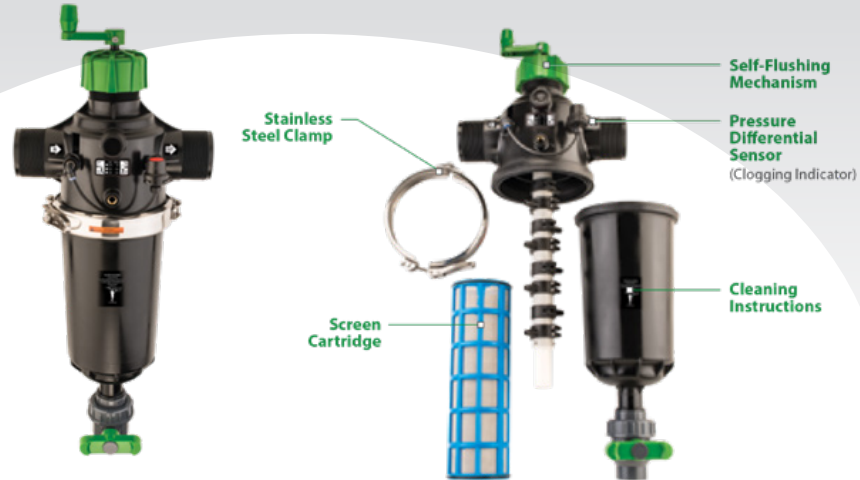

## F6400 PLASTIC SCREEN FILTER

INLET SIZE	FLOW RATE GPM	FILTER AREA	OVER ALL HEIGHT	OVERAL WIDTH	SCREEN MESH	SCREEN TYPE	MAX PSI/ FLUSH PSI	PRICE
2" MPT	44-176	129 IN <sup>2</sup>	33"	13.4"	80, 120, 150	316 SS	150/22	
3" MPT	88-220	197 IN <sup>2</sup>	37"	18.4"	80, 120, 150	316 SS	150/22	

## Head Loss Chart

F6400 Head Loss (psi)/Flow Rate (gpm) 2"

Flow Rate gpm	Head Loss (psi)		
	200 Micron	130 Micron	100 Micron
44	0	0.58	0.37
66	0.25	1.31	1.74
88	0.73	2.03	2.47
110	1.31	2.90	3.34
132	2.03	3.77	4.21
154	3.05	4.69	5.22
176	4.06	5.66	6.38

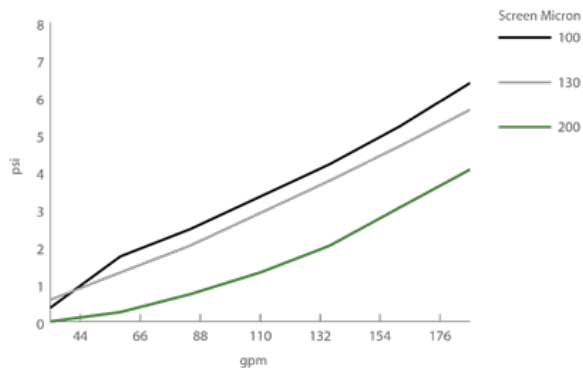

F6400 Head Loss (bar)/Flow Rate (m<sup>3</sup>/h) 3"

Flow Rate gpm	Head Loss (psi)		
	200 Micron	130 Micron	100 Micron
88	0	0.29	0.58
110	0.29	0.58	1.02
132	0.73	1.16	1.60
154	1.31	2.03	2.47
176	2.03	3.05	3.63
198	2.76	4.06	4.79
220	3.48	5.08	5.80

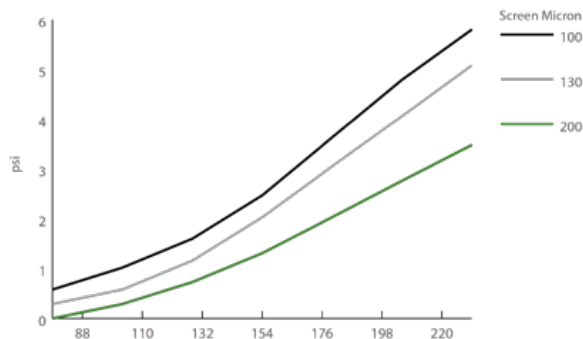

## BAFSCO™ WATERMASTER™ GUIDE

### SPINNER AND FILTER INFORMATION

- THE ACTION FILTER IS EQUIPPED WITH A REMOVABLE STAINLESS STEEL SCREEN. IT SHOULD BE REMOVED AND CLEANED PERIODICALLY AS NEEDED.
- IF SPINNER ROTATION SLOWS DOWN OR STOPS, REMOVE ARMS AND CHECK FOR FOREIGN MATERIAL BUILD UP IN THE ARMS WHICH COULD PLUG THE SPRAY HOLES. SPINNER ARMS SHOULD HAVE THE HOLES AT A 1/4" TURN OR 5° ANGLE FROM TOP DEAD CENTER.
- THE SPINNER BEARING SHOULD BE REMOVED AT LEAST ONCE A YEAR AND CHECKED FOR WEAR ON THE WASHERS. REPLACEMENT PARTS ARE AVAILABLE.

### HELPFUL HINTS ON INSTALLATION

- THE OUTLET TO THE SPINNER MUST BE WELDED INTO THE PIPE ON THE PRESSURE SIDE OF THE PUMP. IT SHOULD BE WELDED BETWEEN THE PUMP DISCHARGE AND THE MAIN DISCHARGE VALVE. THIS ALLOWS ADEQUATE PRESSURE BUILD UP BEHIND THE LARGE DISCHARGE VALVE TO IMMEDIATELY START YOUR WATER MASTER AS YOUR PUMP STARTS.
- SPEED OF ROTATION OF THE SPINNER ARMS CAN BE CONTROLLED BY EITHER THE WATER PRESSURE OR DEGREE OF TILT OF HOLES.
- THE BRASS GATE VALVE SHOULD BE INSTALLED IN THE SPINNER SUPPLY LINE TO CONTROL THE PRESSURE TO THE SPINNER FOR FASTER OR SLOWER ROTATION.
- CHECK THE SPINNER ARMS FOR TIGHTNESS AND MAKE SURE THEY ARE SET TO A 5° OR APPROXIMATELY 1/4" RIGHT TOP DEAD CENTER. FOR SLOWER ROTATION SET THEM LESS THAN 5° AND FOR FASTER ROTATION SET THEM MORE THAN 5° RIGHT TOP OF CENTER.
- THE SPINNER ARMS MUST ALWAYS TURN IN A CLOCKWISE DIRECTION.
- THE SPINNER MUST HAVE A MINIMUM OF 35 PSI TO GIVE IT PROPER PRESSURE TO MAINTAIN A GOOD CLEANING ACTION AND HAVE A ROTATION SPEED OF 45 TO 60 ROTATIONS PER MINUTE.
- MOUNT THE FILTER BRACKET SO THE FILTER WILL HAVE A SLIGHT DOWN SLOPE TOWARDS THE END CAP SO WHEN THE FILTER IS FLUSHED THE DEBRIS WILL FLOW OUT.
- MOUNT THE FILTER IN THE BRACKET WITH THE HOSE CONNECTION IN A HORIZONTAL OR UPWARD POSITION.
- WHEN INSTALLING THE HOSES BE SURE THEY ARE FREE FROM DEBRIS.
- THE SUCTION UNIT SHOULD HAVE A DEPTH OF 2 FEET OR MORE OF WATER OVER THE SCREEN IN ORDER TO GET 100% CAPACITY THROUGH YOUR SYSTEM. LESS THEN THIS CAN REDUCE THE EFFICIENCY OF YOUR PUMPING STATION.
- A SMALLER MESH SCREEN CAN BE USED ON THE WATER MASTER BUT WILL REDUCE THE CAPACITY OF THE WATER MASTER SYSTEM.